

# Liko™ UltraStretch™ accessory

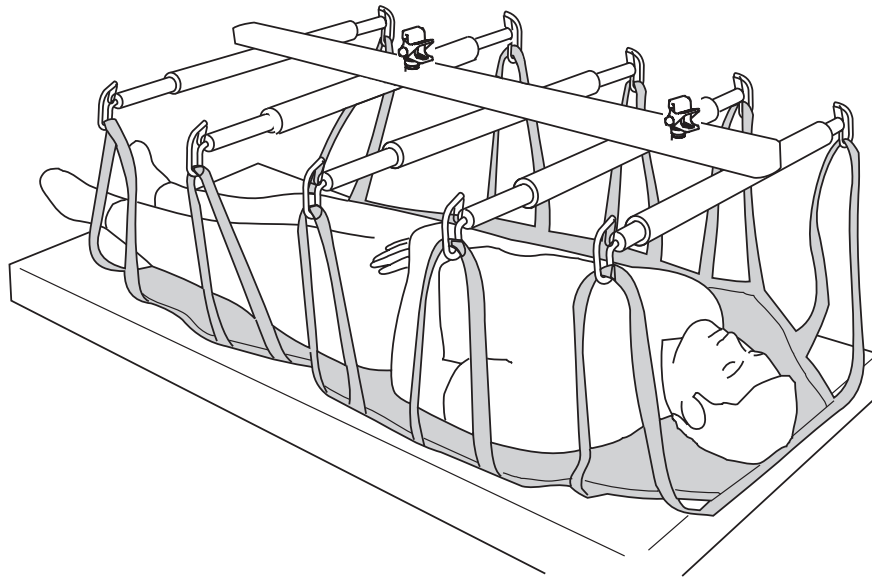

## Instructions for Use

UltraStretch accessory  
Prod. No. 3156058



### Product Description

UltraStretch accessory is intended for lifting and transfer of heavy patients in a fully supine position.

UltraStretch accessory is used in combination with Liko's UltraTwin™ FreeSpan system, with rails 80 cm apart, or with UltraTwin system in a fixed-rail installation.

UltraStretch accessory is easily mounted to the lift units via its Quick-release Hooks. No tools are required. The body support part consists of a lift sheet.

*In this document, the person being lifted is referred to as the patient, and the person helping them is referred to as the caregiver.*

#### **IMPORTANT!**













Lifting and transferring a patient always involves a certain level of risk. Read the instructions for use for both the patient lift and lifting accessories before use. It is important to completely understand the contents of the instructions for use. The equipment should only be used by trained personnel. Ensure that the lifting accessories are suitable for the lift used. Exercise care and caution during use. As a caregiver, you are always responsible for the patient's safety. You must be aware of the patient's ability to make it through the lifting situation. If something is unclear, contact the manufacturer or supplier.

# Table of Contents

Symbol Description .....	3
Safety Instructions .....	4
Dimensions .....	4
Technical Data .....	4
Definitions .....	5
Maximum Load.....	5
Recommended Lifting Accessories .....	5
Assembly .....	5
Lifting with a full sheet.....	6
Lifting after application of sheet.....	7
Care and Maintenance .....	8

# Symbol Description

These symbols can be found in this document and/or on the product.

Symbol	Description
	Warning; this situation requires extra care and attention
	Read instructions for use before use
	CE mark
	Legal manufacturer
	Date of manufacture.
	Caution! consult instructions for use
	Read instructions for use before use
	Head end of the product
	Product Identifier
	Serial Number
	Medical Device
	Recyclable
	GS1 Data Matrix Barcode that may contain following information (01) Global Trade Item Number (11) Production Date (21) Serial Number

## Safety Instructions

**⚠ Before lifting, keep the following points in mind:**

- Ensure that the lifting accessory is properly attached to the lift.
- We recommend that at least two caregivers assist during lifting with FlexoStretch accessory.
- Plan the lifting operation so that it can be done as safely and smoothly as possible.
- Although UltraStretch accessory is equipped with latches, special caution must be exercised. Before the patient is lifted from the underlying surface, but when the straps are fully extended, make sure the straps are correctly connected to the stretcher.
- Make sure that any castors on beds, gurney, etc., are locked during lifting/transferring operation.

**⚠ Never leave a patient unattended during a lifting situation.**

**⚠ The stretcher must not be modified under any circumstance. If you have any questions, please contact Hill-Rom.**

CE Medical Device Class I Product

## Dimensions

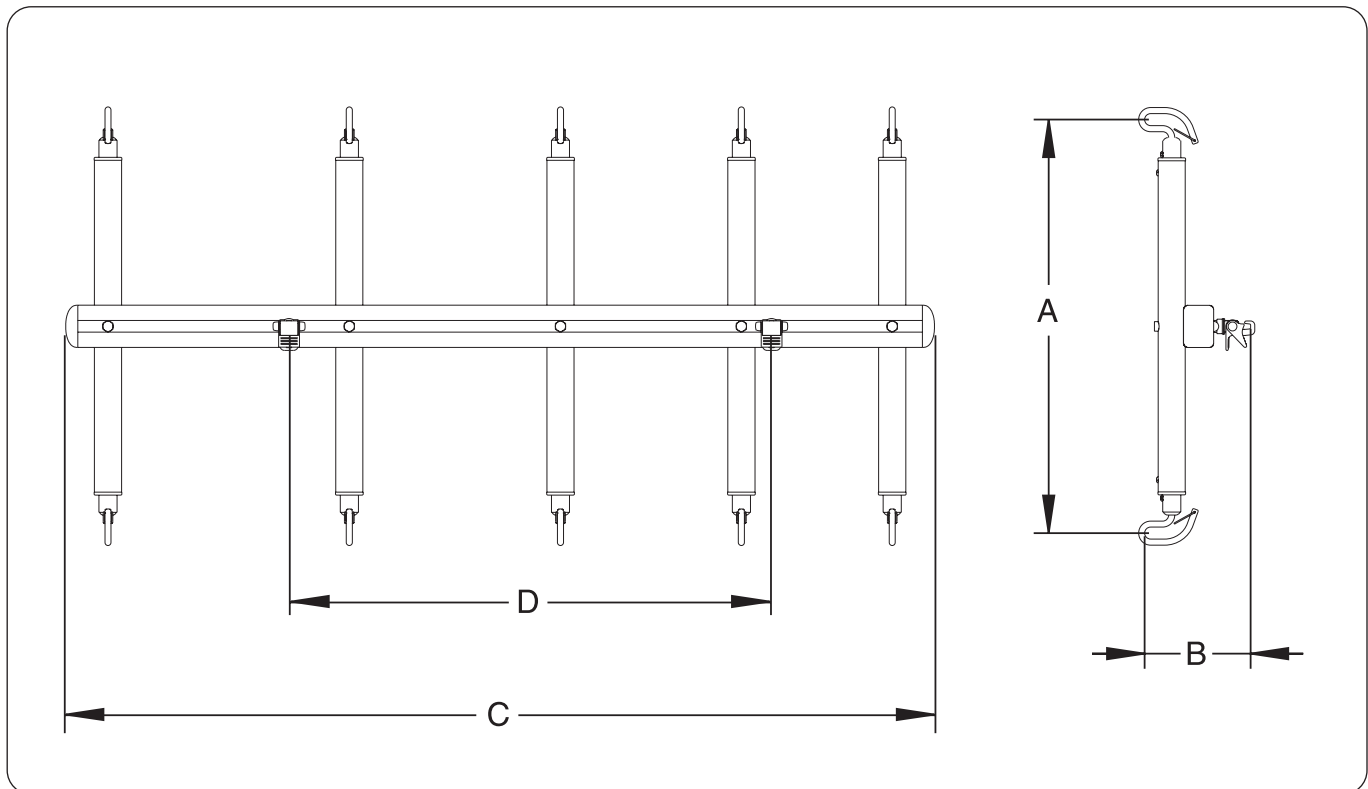

	A	B	C	D	Weight
*	687 - 927	176	1440	800	13,2
**	27 - 36.5	6.9	56.7	31.5	29

\* Weight in kg. Measurements in mm.

\*\* Weight in lbs. Measurements in inches.

## Technical Data

**Maximum load:** 400 kg (880 lbs).  
**Width:** 95 cm (37.4 in.)

## Definitions

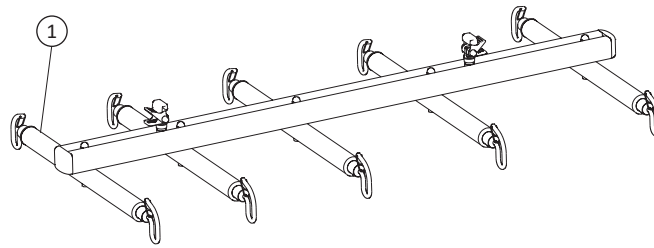

1. Lift Arm

See Recommended lifting accessories page 5.

## Maximum Load

Different maximum loads may apply to different products on the assembled lift system: lift, sling bar, sling and any other accessories used. For the assembled lift system, the maximum load is always the lowest maximum load rating for any of the components. For example: If two Likorall™ 250 lift motors are used in a Ultra system the maximum load for the lift unit is 500 kg (1100 lbs) and if the lift unit is used in combination with UltraStretch™ accessory and a lift sheet which have a maximum load of 400 kg (880 lbs), the maximum load of 400 kg (880 lbs) applies to the assembled lift system.

Study the markings on the lift and lifting accessories or contact your Hill-Rom representative if you have any questions.

## Recommended Lifting Accessories

### LiftSheet™ XL

LiftSheet XL regular (165 cm, 65 inch.)

Prod. No. 3684105

LiftSheet XL long (185 cm 73 inch.)

Prod. No. 3684106

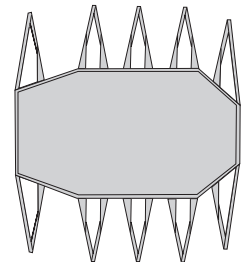

## Assembly

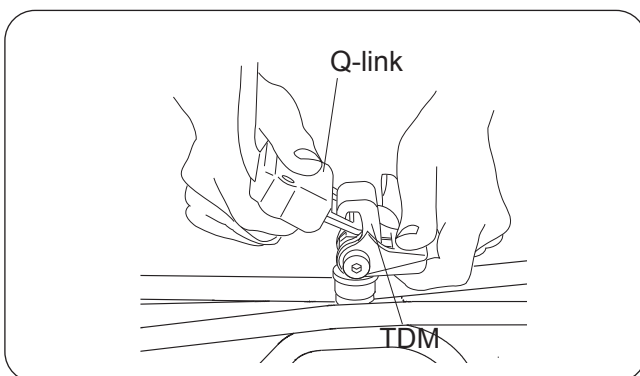

UltraStretch accessory is connected to Liko UltraTwin™ system, a stationary lift system with two lift motors on parallel rails. UltraTwin is mounted independently on Liko's UltraTwin FreeSpan system, with rails 80 cm apart, or on UltraTwin system in a fixed-rail installation.

UltraStretch accessory comes with two TDM Quick-release Hooks, one for each lift unit.

## Lifting with a full sheet

Naturally, when lifting with the full sheet, it is an advantage if the patient is mobile enough to be able to move onto the sheet unassisted. This is sometimes possible prior to surgery.

The operating table is prepared so that the lift sheet is placed under the surgical sheets, enabling the anaesthetized patient to be lifted after the operation.

Here, we present two alternative methods of applying the lift sheet under immobile patients: by turning the patient, and with the help of two sliding sheets.

### Alt. 1) Application of the lift sheet with the help of a stretcher sheet

Turning a heavy patient on one side is a strenuous operation that is easier with the help of an aid such as a stretcher sheet. Two or more caregivers should perform this task.



Turn the patient on one side by pulling the stretcher sheet towards you. ⚠️ Make sure that the patient has enough room in the bed so that there is no risk that he/she will fall to the floor. The bed gate may have to be opened. Make sure that any castors on the bed, gurney, etc. are locked during the lifting/transferring operation.

Position the lift sheet in under the patient as far as possible. The label should be at the head end and face down. Bunch more of the sheet together in folds so that the patient is lying on the centre of the sheet when he/she is turned onto his/her back.



Turn the patient slightly in the opposite direction, so that the lift sheet can be smoothed out. At the same time, prepare to remove the stretcher sheet, if necessary, by folding it in under the patient before he/she is turned onto his/her back.

Turn the patient carefully, so that the stretcher sheet can be removed, if required. Lay the patient gently on his/her back. The patient shall now be positioned on the middle of the lift sheet, with support for the head.

### Alt. 2) Application of the lift sheet with the help of two sliding sheets

If the lift sheet is to be placed under a patient who cannot be turned on one side, a sliding sheet can be used. With the patient lying on his/her back, two folded sliding sheets are pulled into position under the patient and the lift sheet is pulled into place between the sliding sheets. Two or more caregivers should perform this task.

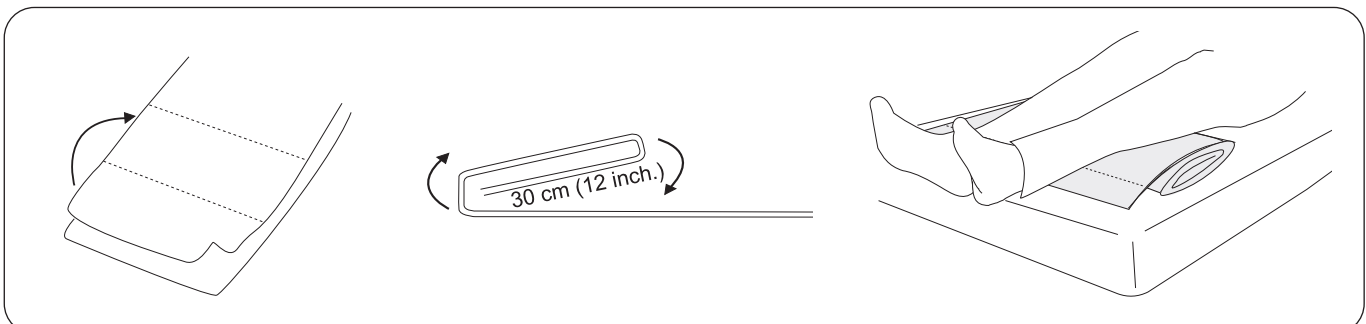

Lay out two sliding sheets, one on top of the other. Start by folding them together, about 30 cm (12 inch.) from the lower edge. Repeat this procedure, folding 30 cm (12 inch.) at a time until the entire length of the two sheets is folded. Turn the sheets so that the in-folds are facing the mattress. Place the folded sheets under the patient's feet and calves.

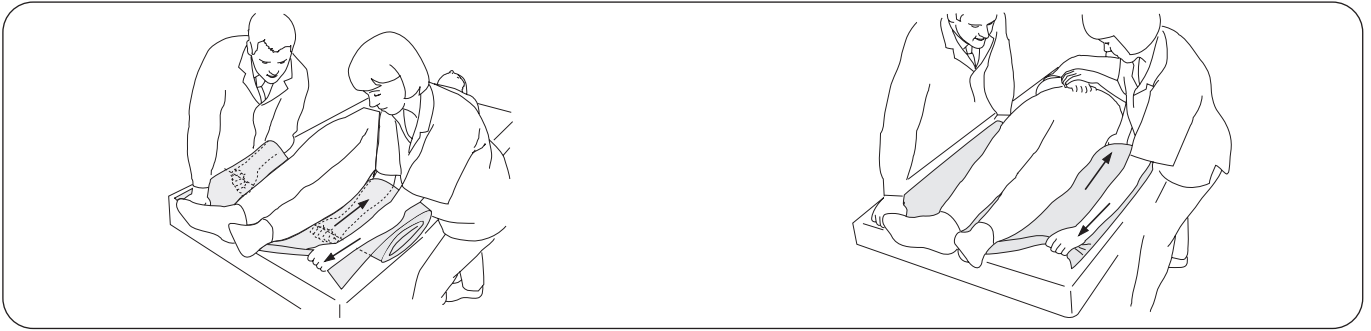

With their arms alongside the patient, the caregivers grasp the fold under the sliding sheets while holding the lower edge of the sheets in place with their other hands.

The caregivers then simultaneously unfold the first fold under the patient. The arms/hands closest to the patient do the unfolding, while the opposite arms/hands hold the lower part of the sheets in place.

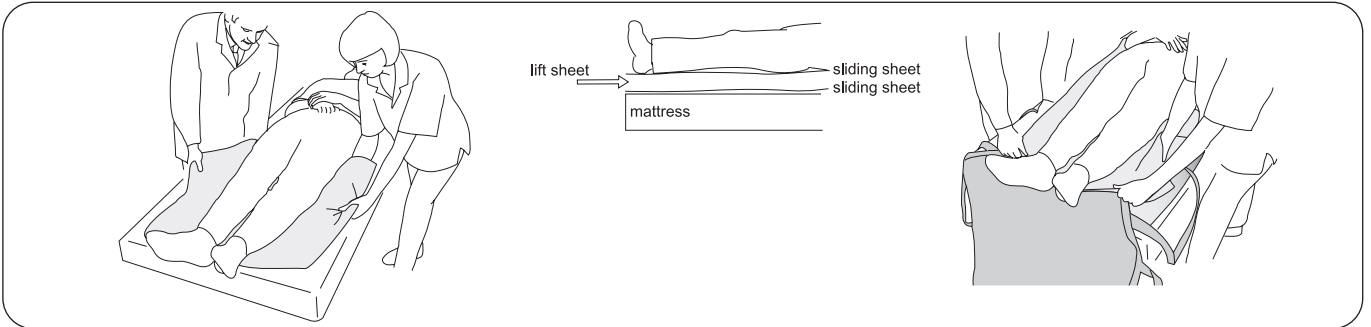

The caregivers then take a firm grip on the next fold and repeat the procedure until the sliding sheets are fully extended under the patient.

The lift sheet is then inserted between the sliding sheets from the foot end and pulled up between the friction-free sliding sheets.

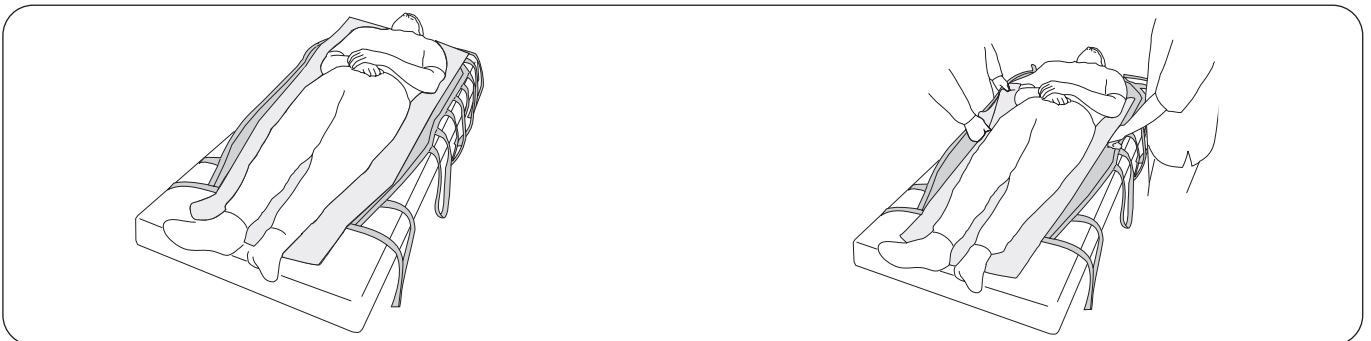

The lift sheet is now in place under the patient. The upper edge should extend far enough that it reaches up under the head.

Now, the top sliding sheet can be removed. The easiest way is to do this from the head end downwards, by doubling the sliding sheet and letting it glide "under itself" as it is pulled downwards.

### Lifting after application of sheet

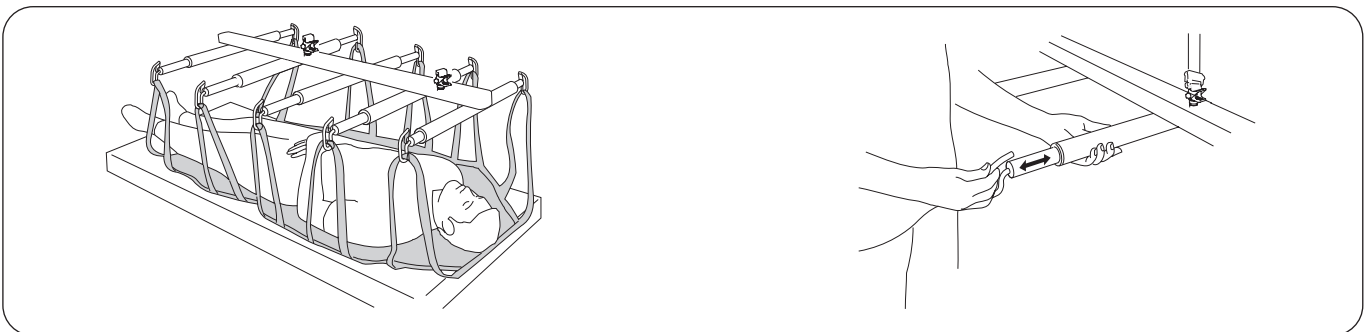

Move UltraStretch™ accessory over the patient and lower it. Hang all the strap loops on the stretcher. Note that the stretcher has a head end and a foot end. Adjust the stretcher width (70 to 95 cm, 27.6 to 37.4 inch.) by extending the liftarms to the appropriate length.

When lifting, ensure that the patient is suspended in the appropriate position: horizontally, or normally somewhat higher at the head end. If necessary, the lifting position can be adjusted by raising or lowering either one of UltraTwin™ system's lift units.

# Care and Maintenance

For trouble-free use, certain details should be checked before each use:

- inspect the stretcher and lifting accessories to make sure that there is no external damage
- check that the safety latches are functioning.

When necessary, clean the stretcher with a moist cloth, using warm water or disinfectants.

**NOTE! Do not use cleaning agents that contain phenol or chlorine, since these can damage aluminum and polyamide material.**

 **The stretcher should not be exposed to running water.**

## Service

A periodic inspection of the stretcher should be carried out at least once per year.

 Periodic inspection should be performed by personnel authorized by Hill-Rom.

 Service activities are not allowed with the patient in the stretcher.

## Service Agreement

Hill-Rom offers the opportunity to enter into service contracts for the maintenance and regular inspection of your Liko product.

## Expected Life Time

The product has an expected service life of 10 years when correctly handled, serviced and periodically inspected in accordance with Liko's instructions.

## Recycling Instructions

The stretcher should be recycled as scrap metal.

Hill-Rom evaluates and provides guidance to its users on the safe handling and disposal of its devices to aid in the prevention of injury, including, but not limited to: cuts, punctures of the skin, abrasions, and any required cleaning and disinfection of the medical device after use and prior to its disposal. Customers should adhere to all federal, state, regional, and/or local laws and regulations as it pertains to the safe disposal of medical devices and accessories.

If in doubt, the user of the device shall first contact Hill-Rom Technical Support for guidance on safe disposal protocols.

## Product Changes

Liko's products undergo continuous development, which is why we reserve the right to make product changes without prior notice. Contact your Hill-Rom representative for advice and information about product upgrades.

## Design and Quality by Liko in Sweden

The management system for both manufacturing and development of the product is certified in accordance with ISO9001 and its equivalent for the medical device industry, ISO13485. The management system is also certified in accordance with the environmental standard ISO14001.

## Notice to Users and/or Patients in EU

Any serious incident that has occurred in relation to the device, should be reported to the manufacturer and the competent authority of the Member State in which the user and/or patient is established.



[www.hillrom.com](http://www.hillrom.com)

 Liko AB  
Nedre vägen 100  
975 92 Luleå, Sweden  
+46 (0)920 474700

Liko AB is a subsidiary of Hill-Rom Holdings Inc.

Enhancing outcomes for  
patients and their caregivers:

**Hill-Rom**